

INSTALLATION INSTRUCTIONS

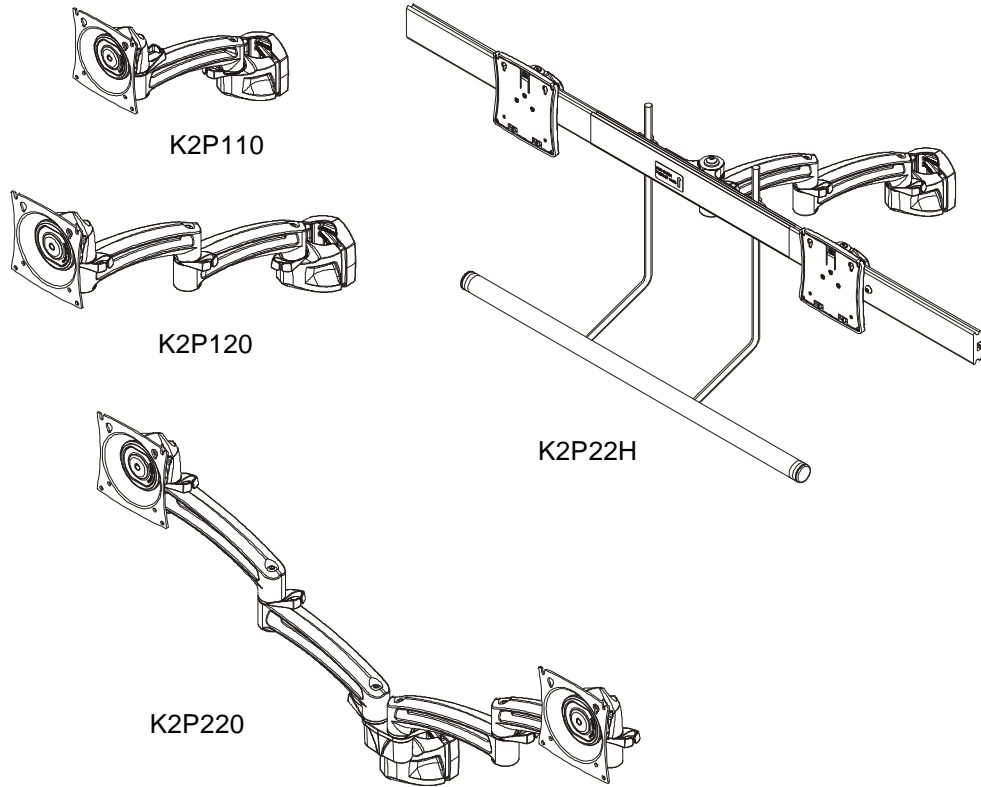

K2P Pole Mounts

DISCLAIMER

Milestone AV Technologies and its affiliated corporations and subsidiaries (collectively “Milestone”), intend to make this manual accurate and complete. However, Milestone makes no claim that the information contained herein covers all details, conditions or variations, nor does it provide for every possible contingency in connection with the installation or use of this product. The information contained in this document is subject to change without notice or obligation of any kind. Milestone makes no representation of warranty, expressed or implied, regarding the information contained herein. Milestone assumes no responsibility for accuracy, completeness or sufficiency of the information contained in this document.

Chief® is a registered trademark of Milestone AV Technologies. All rights reserved.

 **IMPORTANT SAFETY INSTRUCTIONS!**

 **WARNING:** A WARNING alerts you to the possibility of serious injury or death if you do not follow the instructions.

 **CAUTION:** A CAUTION alerts you to the possibility of damage or destruction of equipment if you do not follow the corresponding instructions.

 **WARNING:** Failure to read, thoroughly understand, and follow all instructions can result in serious personal injury, damage to equipment, or voiding of factory warranty! It is the installer’s responsibility to make sure all components are properly assembled and installed using the instructions provided.

 **WARNING:** Failure to provide adequate structural strength for this component can result in serious personal injury or damage to equipment! It is the installer’s responsibility to make sure the structure to which this component is attached can support five times the combined weight of all equipment. Reinforce the structure as required before installing the component.

 **WARNING:** Use this mounting system only for its intended use as described in these instructions. Do not use attachments not recommended by the manufacturer.

 **WARNING:** Never operate this mounting system if it is damaged. Return the mounting system to a service center for examination and repair.

 **WARNING:** Do not use this product outdoors.

 **WARNING:** Exceeding the weight capacity can result in serious personal injury or damage to equipment! It is the installer’s responsibility to make sure the combined weight of all components located between the K2P Series Monitor Arm up to (and including) the display does not exceed the weight limit listed below. Use with products heavier than the maximum weight indicated may result in collapse of the mount and its accessories causing possible injury.

MODEL	Max Weight Allowed for <u>EACH</u> Display	Max Weight Capacity of Mounting System
K2P110	40 lbs (18.14 kg)	40 lbs (18.14 kg)
K2P120	40 lbs (18.14 kg)	40 lbs (18.14 kg)
K2P220	25 lbs (11.34 kg)	50 lbs (22.68 kg)
K2P22H	15 lbs (6.8 kg)	30 lbs (13.6 kg)

--SAVE THESE INSTRUCTIONS!--

DIMENSIONS

K2P110

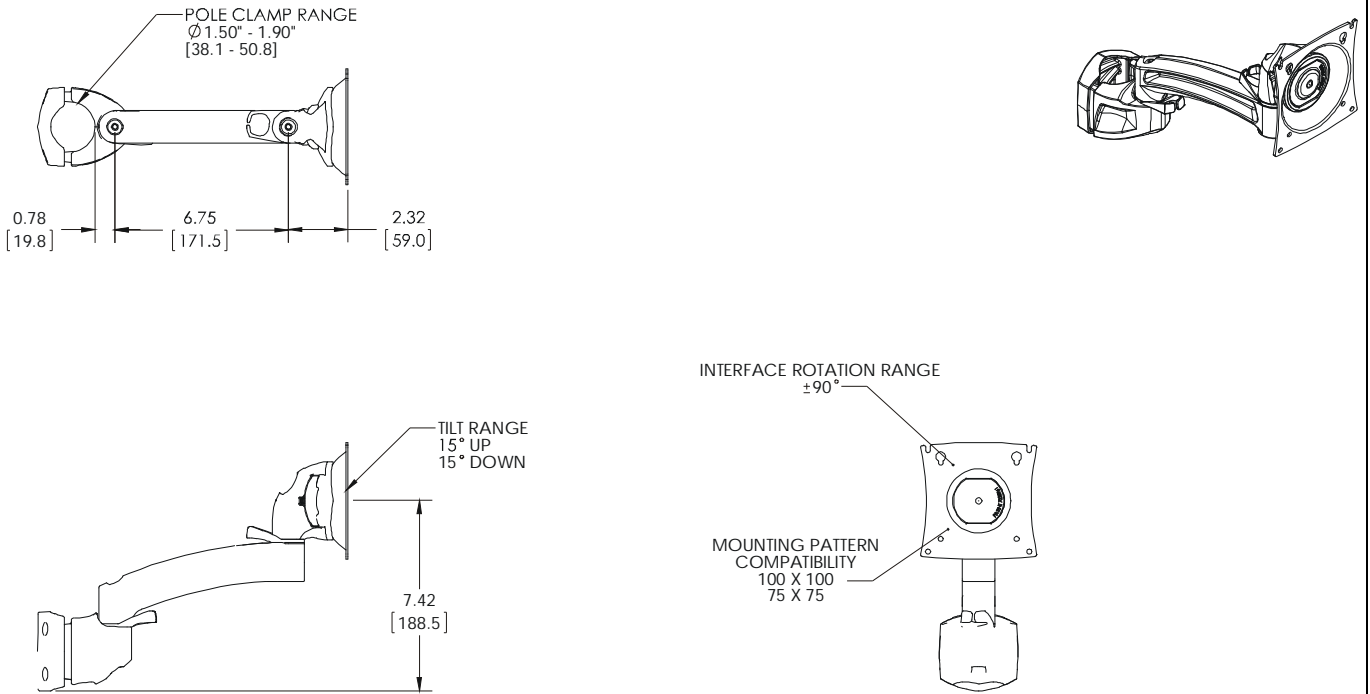



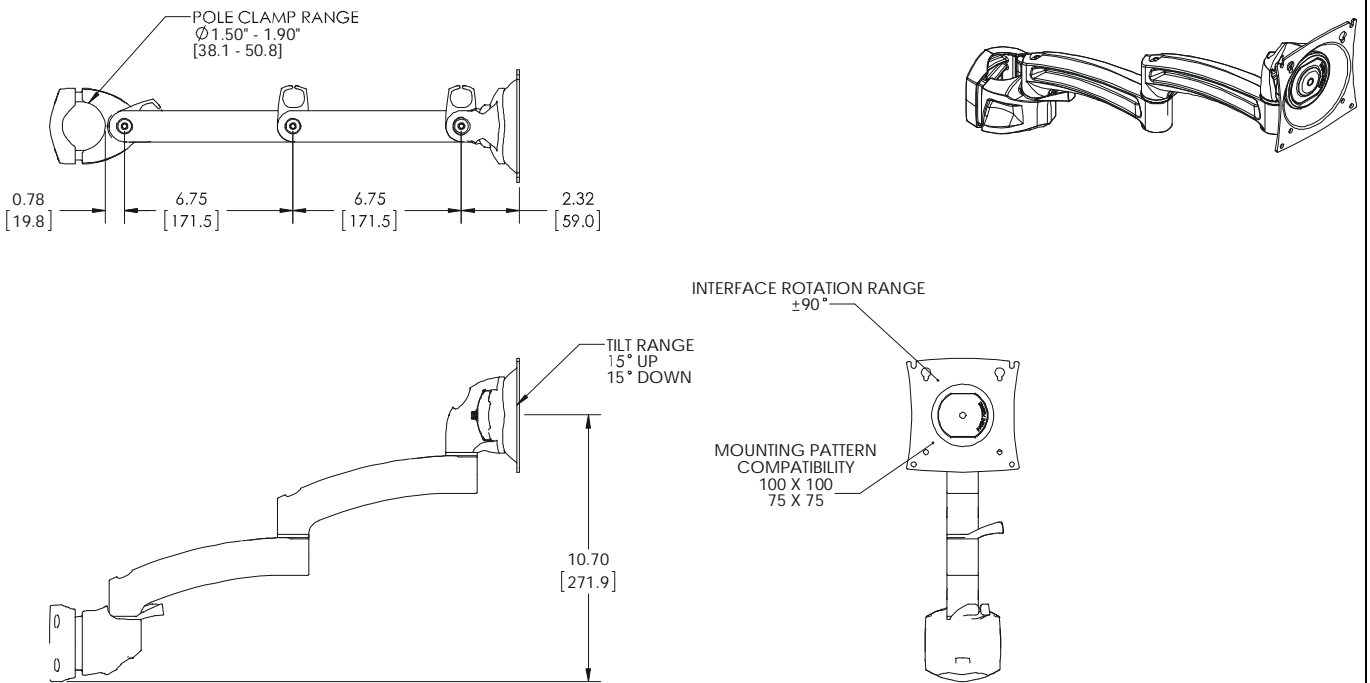

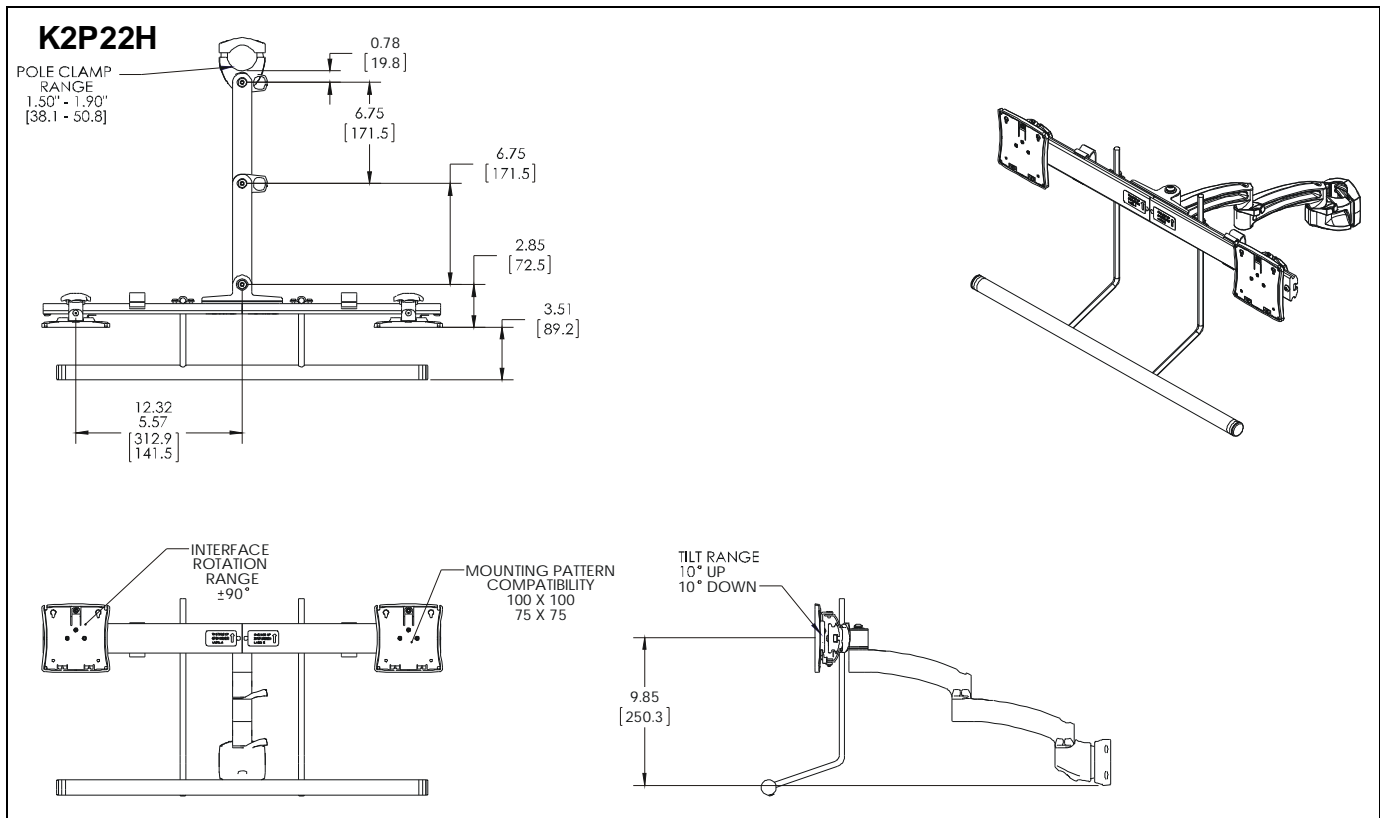
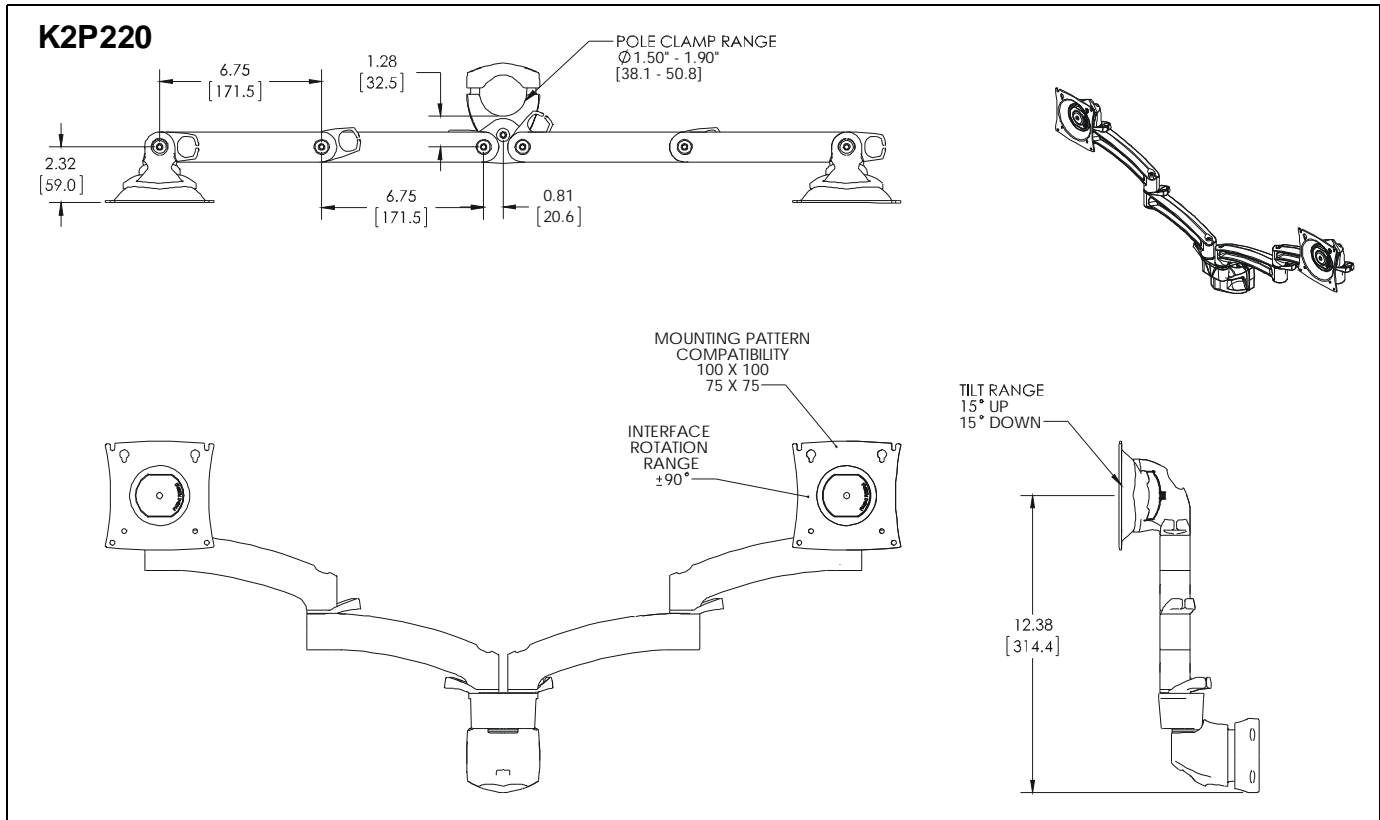



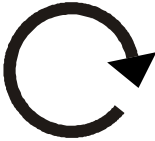

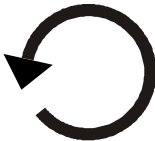

K2P120





LEGEND

	<p>Tighten Fastener</p> <p>Apretar elemento de fijación</p> <p>Befestigungsteil festziehen</p> <p>Apertar fixador</p> <p>Serrare il fissaggio</p> <p>Bevestiging vastdraaien</p> <p>Serrez les fixations</p>		<p>Pencil Mark</p> <p>Marcar con lápiz</p> <p>Stiftmarkierung</p> <p>Marcar com lápis</p> <p>Segno a matita</p> <p>Potloodmerkteken</p> <p>Marquage au crayon</p>
	<p>Loosen Fastener</p> <p>Aflojar elemento de fijación</p> <p>Befestigungsteil lösen</p> <p>Desapertar fixador</p> <p>Allentare il fissaggio</p> <p>Bevestiging losdraaien</p> <p>Desserrez les fixations</p>		<p>Drill Hole</p> <p>Perforar</p> <p>Bohrloch</p> <p>Fazer furo</p> <p>Praticare un foro</p> <p>Gat boren</p> <p>Percez un trou</p>
	<p>Phillips Screwdriver</p> <p>Destornillador Phillips</p> <p>Kreuzschlitzschraubendreher</p> <p>Chave de fendas Phillips</p> <p>Cacciavite a stella</p> <p>Kruiskopschroevendraaier</p> <p>Tournevis à pointe cruciforme</p>		<p>Adjust</p> <p>Ajustar</p> <p>Einstellen</p> <p>Ajustar</p> <p>Regolare</p> <p>Afstellen</p> <p>Ajuster</p>
	<p>Open-Ended Wrench</p> <p>Llave de boca</p> <p>Gabelschlüssel</p> <p>Chave de bocas</p> <p>Chiave a punte aperte</p> <p>Steeksleutel</p> <p>Clé à fourche</p>		<p>Remove</p> <p>Quitar</p> <p>Entfernen</p> <p>Remover</p> <p>Rimuovere</p> <p>Verwijderen</p> <p>Retirez</p>
	<p>By Hand</p> <p>A mano</p> <p>Von Hand</p> <p>Com a mão</p> <p>A mano</p> <p>Met de hand</p> <p>À la main</p>		<p>Optional</p> <p>Opcional</p> <p>Optional</p> <p>Opcional</p> <p>Opzionale</p> <p>Optie</p> <p>En option</p>
	<p>Hex-Head Wrench</p> <p>Llave de cabeza hexagonal</p> <p>Sechskantschlüssel</p> <p>Chave de cabeça sextavada</p> <p>Chiave esagonale</p> <p>Zeskantsleutel</p> <p>Clé à tête hexagonale</p>		<p>Security Wrench</p> <p>Llave de seguridad</p> <p>Sicherheitsschlüssel</p> <p>Chave de segurança</p> <p>Chiave di sicurezza</p> <p>Veiligheidssleutel</p> <p>Clé de sécurité</p>

TOOLS REQUIRED FOR INSTALLATION

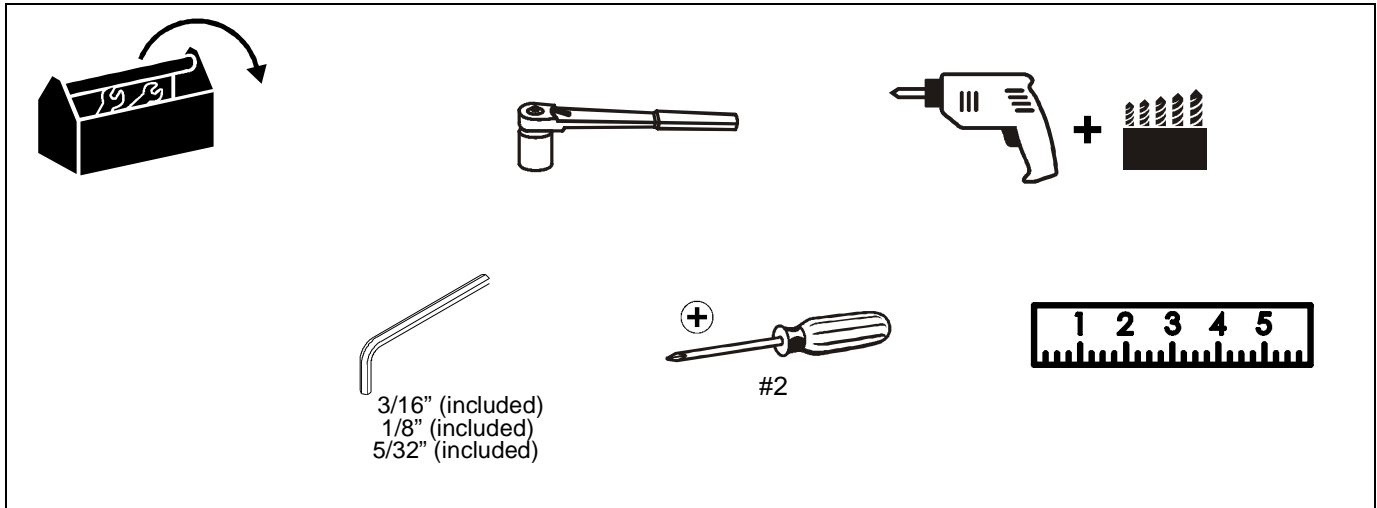

PARTS

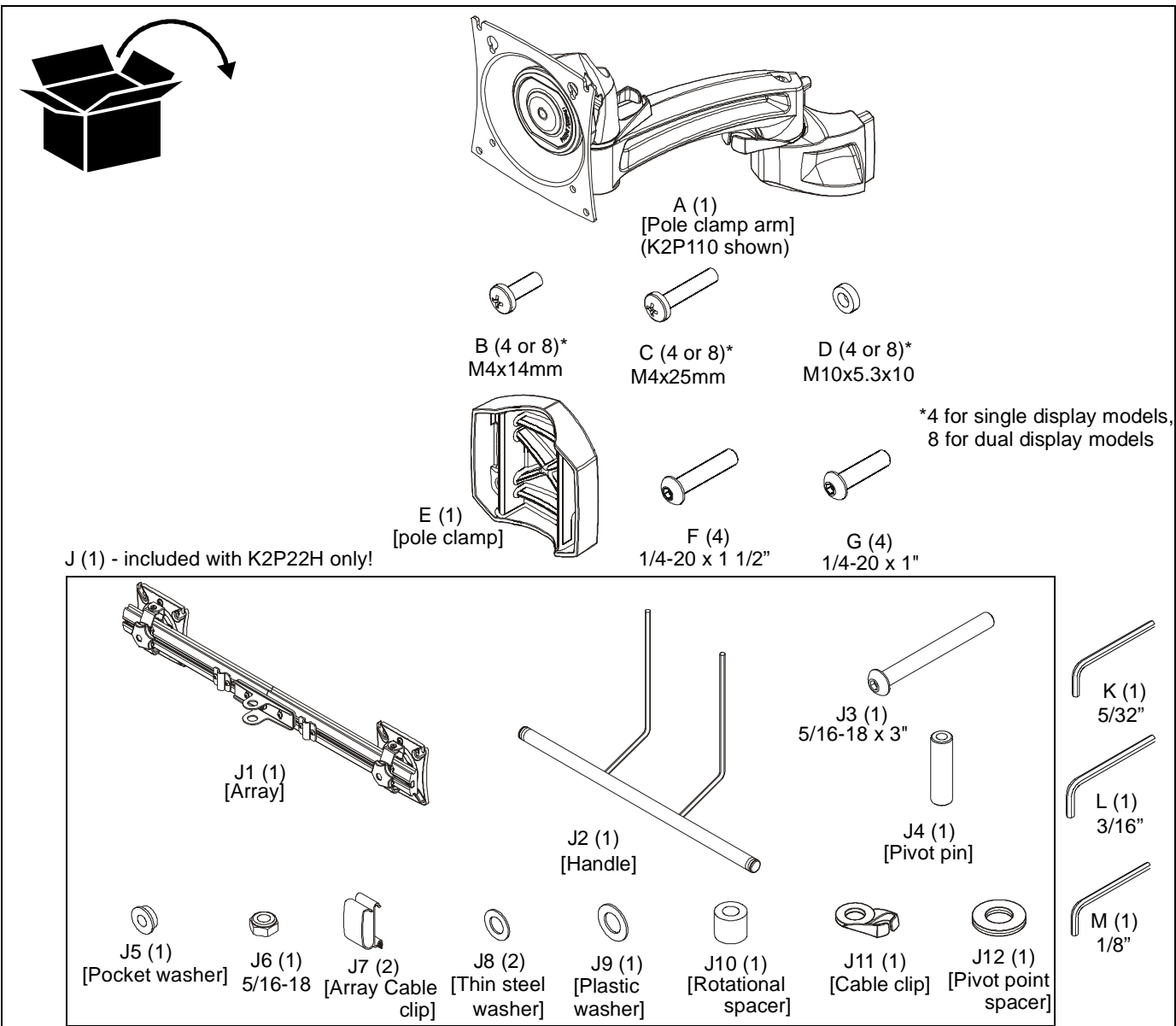

Assembly And Installation

Connecting to Pole

1. Determine approximate location for mount keeping in mind display size, extension, height adjustment requirements.
2. Place mount (A) against pole with clamp (E) on opposite side of pole. (See Figure 1)

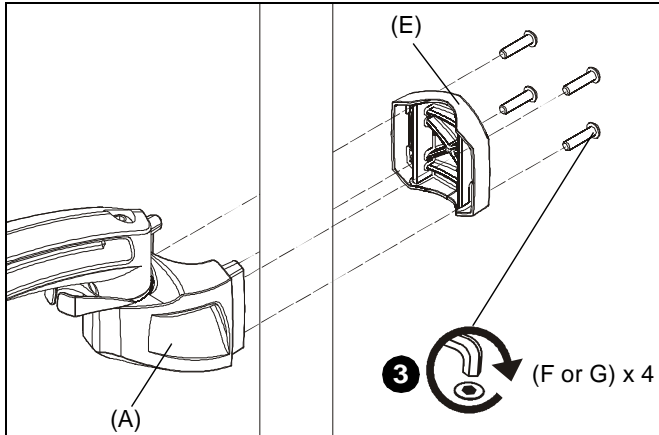

Figure 1

3. Using 5/32" hex key (K) and appropriate length screws, loosely attach assembly to pole clamp (E). If installing to 1 1/2" NPT pipe, use 1/4-20 x 1 1/2" button head cap screws (F). If installing to 1 1/2" diameter pipe, use 1/4-20 x 1" button head cap screws (G). (See Figure 1)
4. Position mount at desired height and orientation.
5. Equally tighten screws against mount and the pole clamp.

Array Installation (K2C22H and K2C22HSXF1 Models ONLY)

1. Slide rotational spacer (J10) into opening on array attachment bracket. (See Figure 2)
2. Use 5/16-18 x 3" button head cap screw (J3), two thin steel washers (J8), plastic spacer (J9), pocket washer (J5), pivot pin (J4), pivot point spacer (J12) and 5/16-18 lock nut (J6) to secure array (J1) to K2 arm (A). (See Figure 2)

NOTE: Cable clip (J11) can be used in place of pivot point spacer (J12) if additional cable management is desired. (See Figure 2)

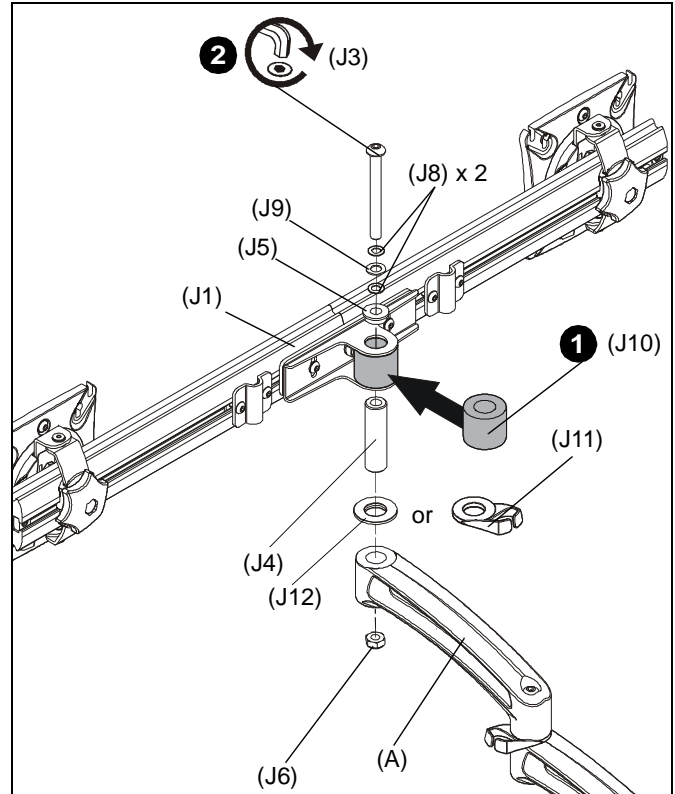

Figure 2

Display Installation



WARNING: Exceeding the weight capacity can result in serious personal injury or damage to equipment! It is the installer's responsibility to make sure the combined weight of all components located between the K2P Series Monitor Arm up to (and including) the display does not exceed the weight limit listed below. Use with products heavier than the maximum weight indicated may result in collapse of the mount and its accessories causing possible injury.

MODEL	Max Weight Allowed for <u>EACH</u> Display	Max Weight Capacity of Mounting System
K2P110	25 lbs (11.34 kg)	25 lbs (11.34 kg)
K2P120	25 lbs (11.34 kg)	25 lbs (11.34 kg)
K2P220	25 lbs (11.34 kg)	50 lbs (22.68 kg)
K2P22H	9 lbs (4.08 kg)	18 lbs (8.16 kg)

K2P110, K2P120 AND K2P220

NOTE: K2P22H mount has K1 Series faceplates on array arm.
Proceed to K2P22H Section.

The mounting holes on the back of the display will either be flush with the back surface or recessed into the back surface. Refer to the applicable installation procedure.

Flush Mounting Holes



CAUTION: Using screws of improper size may damage your display! Proper screws will easily and completely thread into display mounting holes.



CAUTION: Inadequate thread engagement in display may cause display to fall! Back out screws **ONLY** as necessary to allow installation of Centris bracket!

1. Ensure faceplate is able to swivel and tilt easily, yet still be tight enough to hold display in desired position. Adjust as required before proceeding. See "ADJUSTMENT" for detail. (See Figure 3)
2. Using Phillips screwdriver, carefully install two M4x14mm screws (B) into the *upper* mounting holes on the display. Thread screws completely into display, then back out 3 complete turns. (See Figure 3)
3. Pick up and align display so that screws (B) (installed on the back of the display in the previous step) fit into the mounting holes on the faceplate. Rotate the bracket as required. Lower the display firmly into place. (See Figure 3)

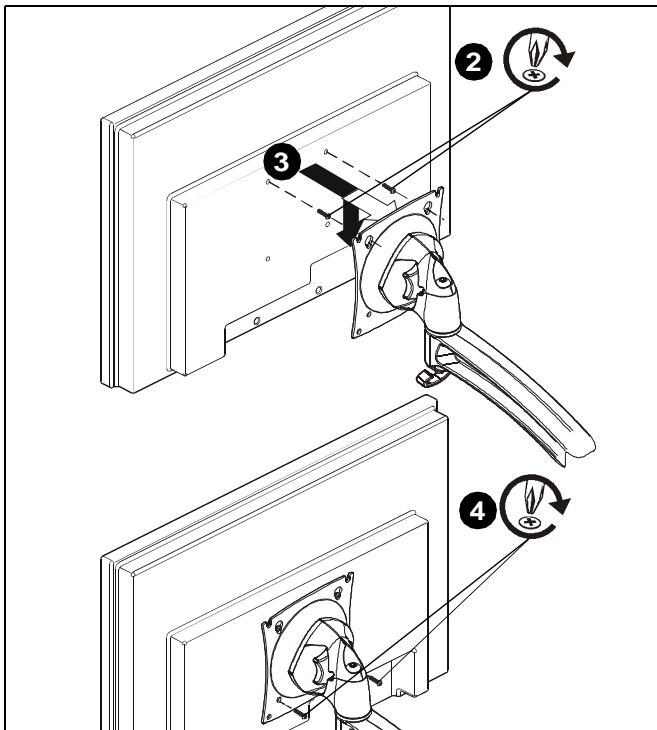

Figure 3

4. Using Phillips screwdriver, install two remaining M4x14mm Phillips screws (B) through the *lower* mounting holes in faceplate into the display. (See Figure 3)
5. Tighten all four screws (B). Do not overtighten!

Recessed Mounting Holes

1. Ensure Centris bracket is able to swivel and tilt easily, yet still be tight enough to hold display in desired position. Adjust as required before proceeding. See "ADJUSTMENT" for detail.
2. Carefully place display face down on protective surface.
3. Place the four spacers (D) over each of the mount holes on the back of the display. (See Figure 4)
4. Pick up and orient the mount (A) so that the mounting holes are aligned with the holes in the spacers; rotate the bracket as required. (See Figure 4)
5. Using Phillips screwdriver, install four M4x25mm screws (C) through the mounting holes, through the spacers and into the display. (See Figure 4)
6. Tighten all four screws. Do not overtighten!

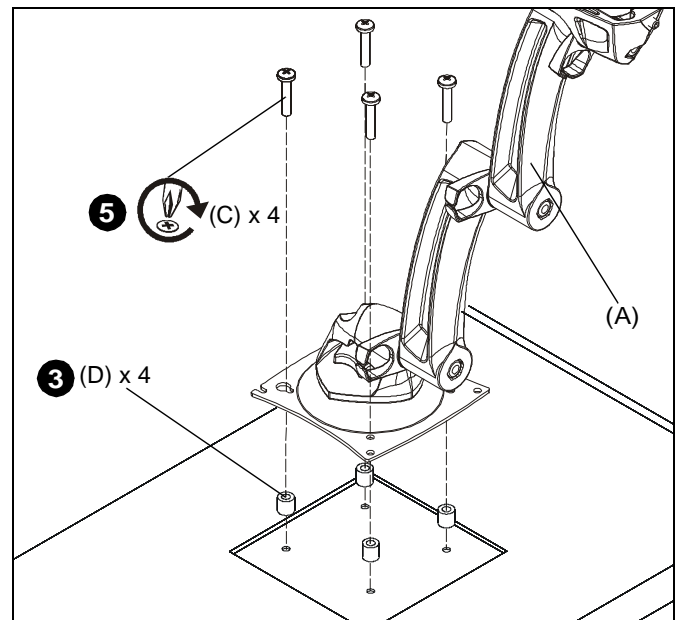

Figure 4

K2P22H

1. Remove quick release faceplate from mount by pulling quick release lever and sliding faceplate off mount. (See Figure 5)

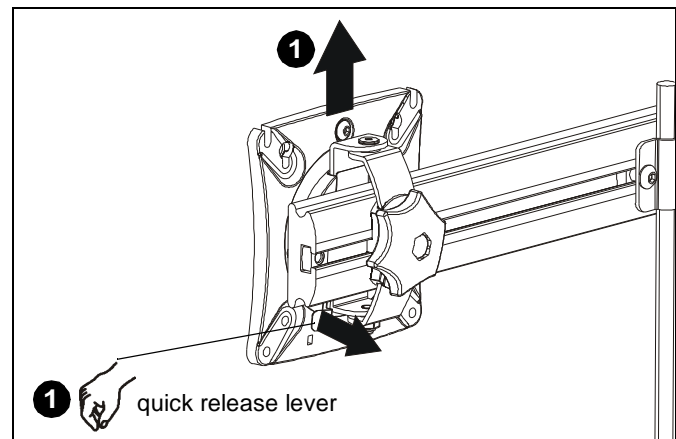

Figure 5



WARNING: Only remove display from mount when the display can be lifted up from the mount! DO NOT remove display unless the display is in the upright position! See Display Removal section for details.

2. Carefully place display face down on protective surface.
3. Connect faceplate to display

For flush mounting hole installation:

- Using Phillips screwdriver, carefully install four M4x14mm screws (B) through corresponding holes on faceplate and into the mounting holes on the display. (See Figure 6)

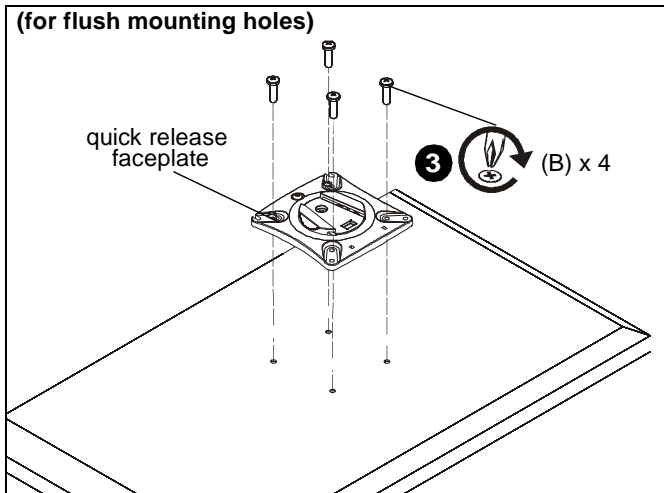

Figure 6

For recessed mounting hole installation:

- Place four spacers (D) on top of mounting holes on back of display. (See Figure 7)
- Using Phillips screwdriver, carefully install four M4x25mm screws (C) through corresponding holes on faceplate, spacers (D) and into the mounting holes on the display. (See Figure 7)

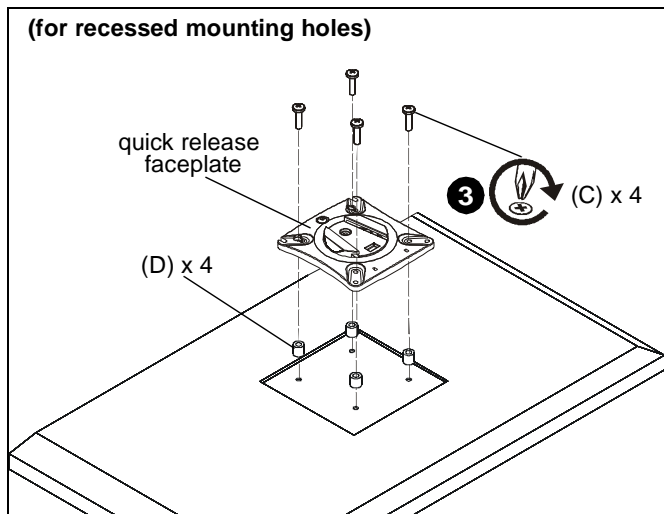

Figure 7

4. Position display with faceplate attached above mount. (See Figure 8)
5. Slide faceplate onto mounting head until quick release tab clicks into place. (See Figure 8)

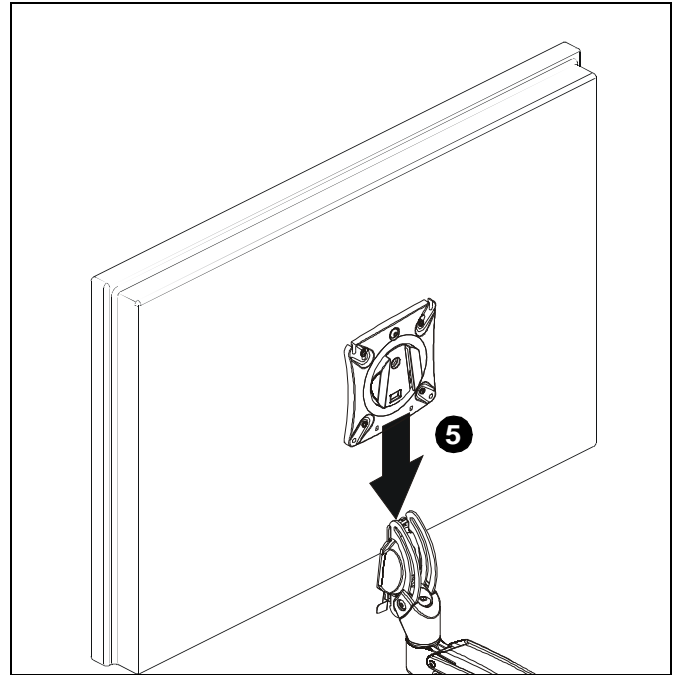

Figure 8

Handle Installation (K2P22H models only)

1. Loosen four screws securing handle brackets to K2P22H array. (See Figure 9)
2. Install uprights of handle (J2) into handle brackets located on the back of K2P22H array. (See Figure 9)

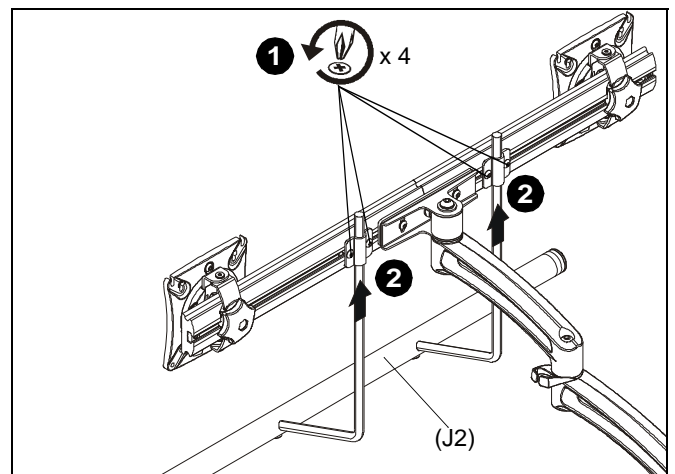

Figure 9

3. Position handle (J2) at desired height and secure by tightening button head cap screws attaching handle brackets to array. (See Figure 10)

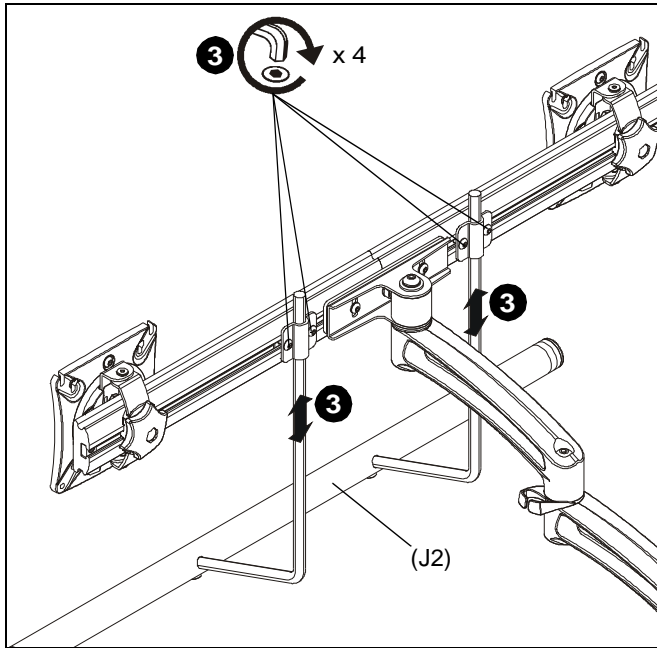

Figure 10

Adjustments

Portrait Adjustment (K2P22H Models only)

1. The monitor may be adjusted 90 degrees in either direction in order to provide a portrait view of the monitor. (See Figure 11)
2. Use 1/8" hex key (M) to adjust rotational adjustment screw to adjust rotational tension. (See Figure 11)

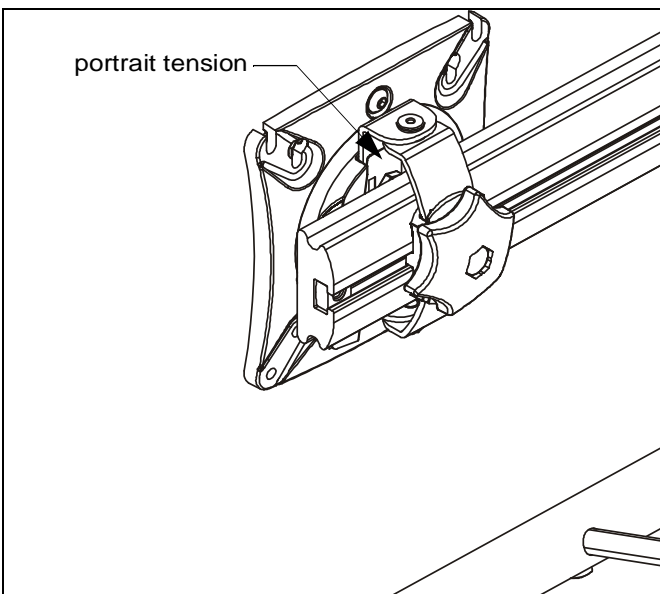

Figure 11

Adjustments - K2P22H models only

1. Loosen knobs securing faceplates to array. (See Figure 12)
2. Slide displays laterally on array to adjust lateral shift. (See Figure 12)
3. Adjust pitch and pivot position as desired. (See Figure 12)
4. Tighten knobs to secure faceplates in position. (See Figure 12)

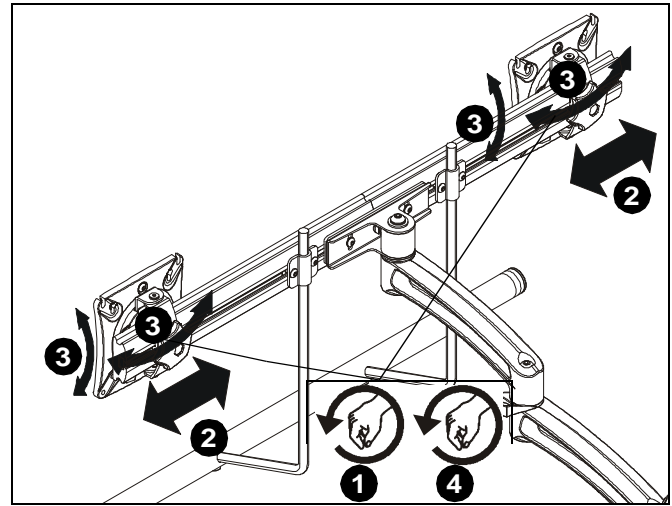

Figure 12

Array Bar Roll Adjustment

1. Loosen roll adjustment screws on back of array bracket. (See Figure 13)
2. Adjust roll of array bar as desired. (See Figure 13)
3. Tighten roll adjustment screws on back of array bracket. (See Figure 13)

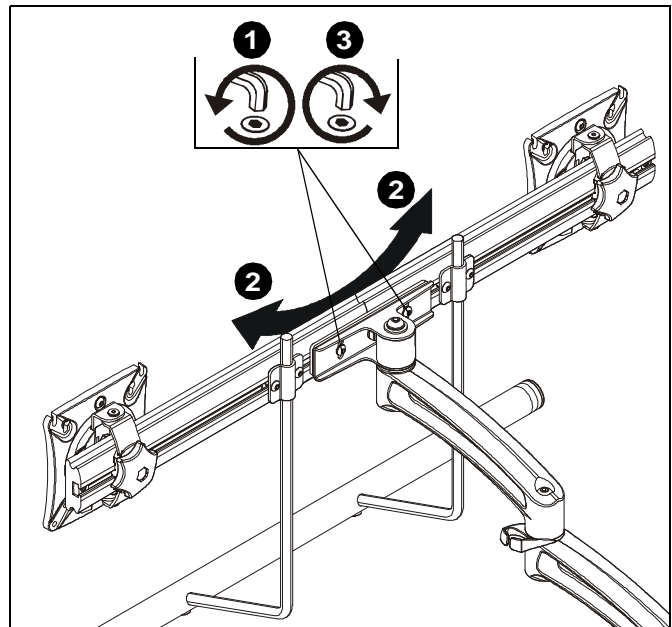

Figure 13

Swing Arm Pivot Adjustment

1. Adjust pivot position as desired. (See Figure 14)
2. Adjust pivot point tension screws to change pivot adjustment tension. (See Figure 14)

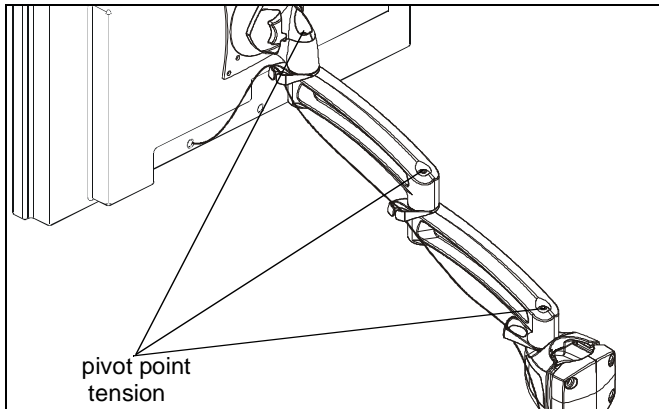

Figure 14

Cable Management Non-Array Models

1. Route cables through cable management channels. (See Figure 15)

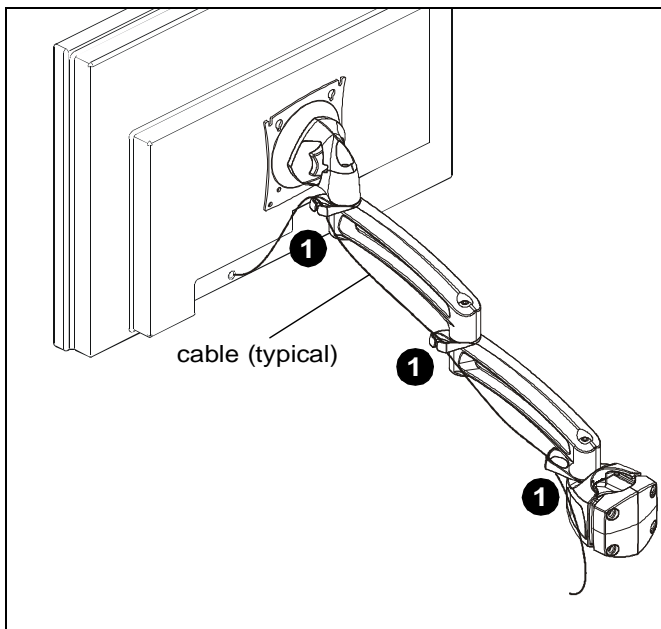

Figure 15

Array Models

1. Install cable clips (J7) to back of array. (See Figure 16)
2. Route cables through cable clips (J7) as desired. (See Figure 16)

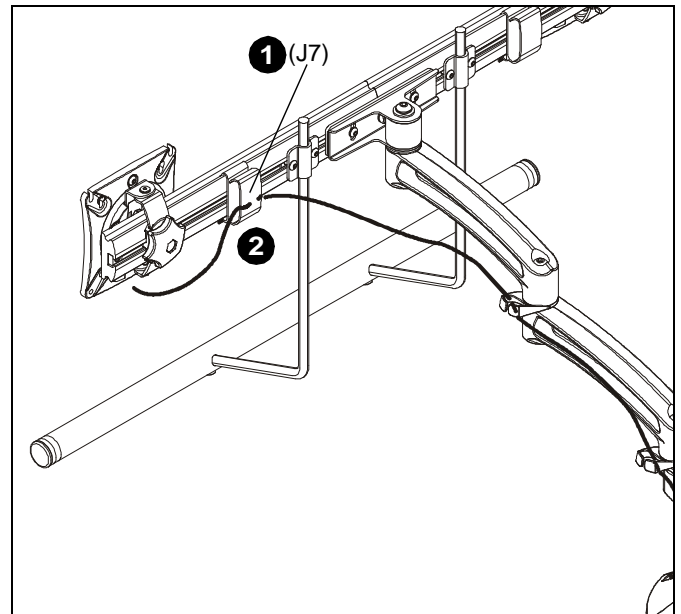

Figure 16



Our Mounts. **Your Vision.**

Chief, a products division of
Milestone AV Technologies

8800-002482 Rev00
©2014 Milestone AV Technologies
www.chiefmfg.com
03/14

USA/International	A 6436 City West Parkway, Eden Prairie, MN 55344 P 800.582.6480 / 952.225.6000 F 877.894.6918 / 952.894.6918
Europe	A Franklinstraat 14, 6003 DK Weert, Netherlands P +31 (0) 495 580 852 F +31 (0) 495 580 845
Asia Pacific	A Office No. 918 on 9/F, Shatin Galleria 18-24 Shan Mei Street Fotan, Shatin, Hong Kong P 852 2145 4099 F 852 2145 4477

